

Integral Bonnet Needle Valves VN5

Needle Valves

VN5 Needle Valve	149
VN6 Needle Valve	157
VU6 Union Bonnet Valve	161



Integral Bonnet Needle Valves VN5

CONTENTS

Features	150	VN5 series	152
Materials of Construction	150	VN5A series	154
Application	151	Pressure-Temperature Rating	155
Cleaning	151	Handle Turns-Flow Coefficient	155
Testing	151	Stem Types	156
Important Notification	151	Handle Types	156
How To Order	151		

Features

- Pressure rating up to 5000psig (340bar) @38°C (100°F)
- Temperature rating from -53°C(-65°F) to 232°C (450°F) with standard PTFE packing, up to 315°C(600°F) with PEEK packing
- Compact forged body with straight and angle pattern for design of miniaturized fluid systems
- Hardened stem threads and forged body for long cycle life

- Integral bonnet design to eliminate unintentional stem back-out
- Panel mounting without packing disruption
- Wide choices of port sizes and end connections

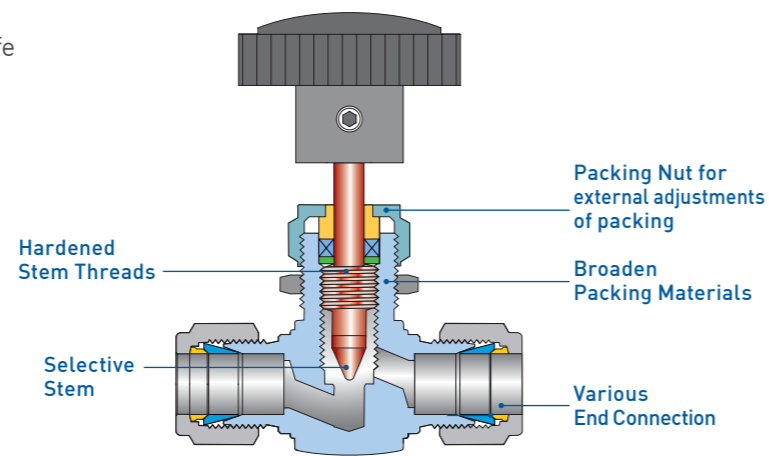
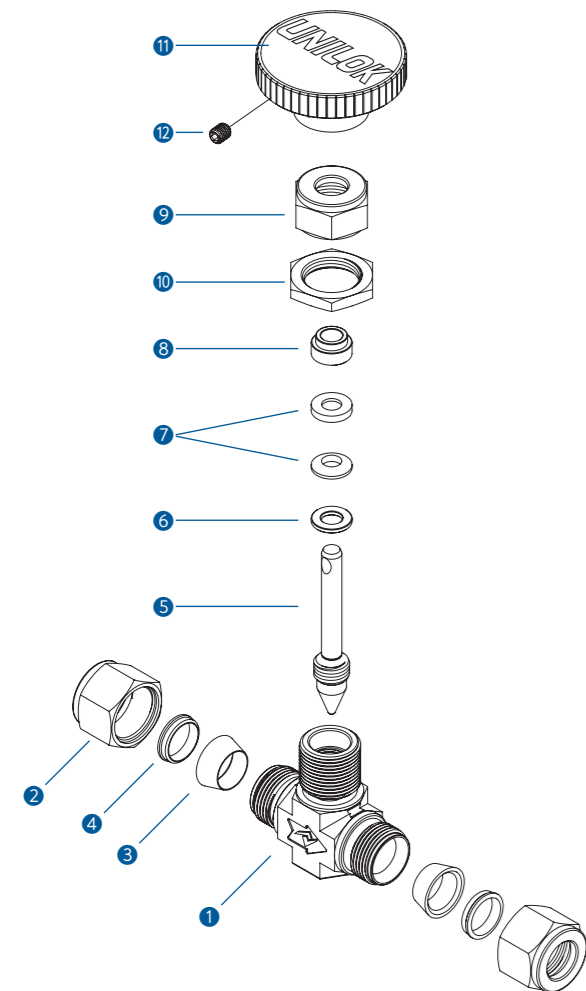

Materials of Construction

No.	Description	Materials		
	Body Material	316SS	Brass	Alloy 400
1	Body	316SS	Brass	Alloy 400
2	Nut	316SS	Brass	Alloy 400
3	Front Ferrule	316SS	Brass	Alloy 400
4	Back Ferrule	316SS	Brass	Alloy 400
5	Stem	316SS	Brass	Alloy R-405/B164
6	Packing Ring	316SS	Brass	Alloy R-405/B164
7	Packing	PTFE		
8	Packing Gland	316SS	Brass	Alloy R-405/B164
9	Packing Nut	316SS	Brass	Alloy R-405/B164
10	Panel Nut	316SS	Brass	316SS
11	Handle	Nylon with brass insert		
12	Handle Screw	304SS		

Application

Regulation and shut-off of fluids and gases for wide range of general purpose
 Sampling systems, laboratories, corrosive and high pressure service, valves - pressure gauge and cylinder, panel board instrumentation

Sour Environment Services

UNILOK valves comply with NACE MR-0175/ISO 15156 for sour oilfield application or NACE MR-0103 for petroleum refining operations.
 To order, add-N to the end of part number.

Cleaning

UNILOK valves are free from machine oils, loose particles and grease throughout the close cleaning process.

How To Order

UNILOK VN5 series needle valves are ordered by part number as shown below.

Testing

Every valve is 100% factory tested with air and nitrogen at 1000psig(69bar) for leakage at the seat and packing. Each test is performed to a maximum allowable leak rate of 0.1scc/min.

Important Notification

Proper installation, materials compatibility, operation and maintenance of these valves are the responsibility of the user. The total system design must be taken into consideration to ensure optimal performance and safety.
 The packing adjustment may be required during the valve's service life.

Example: The following part number, *VN52U-04T-SS* is designated for VN5 series needle valve with both 1/4" UNILOK tube fitting, 316SS, round handle.



Valve Type	
N5	Straight Pattern
N5A	Angle Pattern

Connection Size							
Fractional(Inch) Tube O.D. Designation							
Tube O.D.	inch	1/8	1/4	3/8	1/2	3/4	1
	mm	3.17	6.35	9.52	12.70	19.05	25.40
Designator		02T	04T	06T	08T	12T	16T

Body Materials	
SS	316SS
BS	Brass
MO	Alloy 400

Other alloys are available upon request.

Connection Type	
U	UNILOK Tube Fitting
F	Female NPT or ISO7/1(PT)
M	Male NPT or ISO7/1(PT)
WS-	Socket Weld -Tube
WS-	Socket Weld - Pipe

Metric Tube O.D. Designation						
Tube O.D.	mm	6	8	10	12	16
	Designator	M06T	M08T	M10T	M12T	M16T

Stem Type	
None	Vee Stem
R	Regulating Stem
S	Soft-seat Stem

Pipe Size Designation (NPT or ISO7/1-PT)				
Pipe Size	1/8	1/4	3/8	1/2
Designator	02N/R	04N/R	06N/R	08N/R

Packing Materials	
None	PTFE
PK	PEEK

Weld Size Designation			
Tube Size	1/4	3/8	1/2
Designator	04T	06T	08T
Pipe Size	1/4	3/8	1/2
Designator	04P	06P	08P

Handle Type	
None	Nylon Round Handle
B	Bar Handle

VN5 series

(Straight Pattern, Both UNILOK Tube Fittings or Both Female or Male Threads)

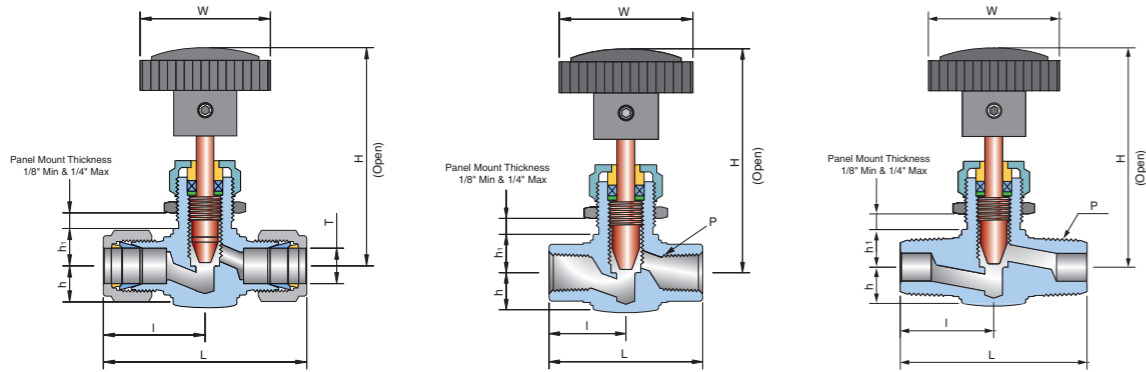

Ordering Information & Dimensions

Part No.	End Connections		Orifice	CV	Dimensions (mm)					Panel Hole Drill Size	
	Inlet	Outlet			L	I	h	h ₁	Round Handle H(open) W		
VN51	U-02T-	1/8" UNILOK	2.0	0.09	49.3	24.9	11.2	7.9	57.9	25.4	11.9
	U-M03T-	3mm UNILOK			49.3	24.9					12.2
	F-02N-	1/8" Female NPT			47.8	23.9					11.9
	M-02N-	1/8" Male NPT			38.1	19.1					
VN52	U-04T-	1/4" UNILOK	4.3	0.37	56.3	28.2	9.5	9.5	65.9	34.7	13.5
	U-M06T-	6mm UNILOK			56.8	28.4					
	U-M08T-	8mm UNILOK			59.0	29.5					
	F-02N-	1/8" Female NPT			42.0	21.0					
	M-02N-	1/8" Male NPT			41.2	20.6					
	M-04N-	1/4" Male NPT			50.0	25.5					
VN53	U-06T-	3/8" UNILOK	6.3	0.73	67.8	33.9	12.5	13.5	80.6	46.7	20.0
	U-08T-	1/2" UNILOK			73.2	36.6					
	U-M10T-	10mm UNILOK			67.4	33.7					
	U-M12T-	12mm UNILOK			73.4	36.7					
	F-04N-	1/4" Female NPT			54.0	27.0					
	M-06N-	3/8" Male NPT			53.0	26.5					
	MF-04N-	1/4" Male NPT 1/4" Female NPT			55.6	26.5					
VN54	U-08T-	1/2" UNILOK	9.5	1.80	83.2	41.6	17.0	17.0	97.0	55.5	23.0
	U-12T-	3/4" UNILOK			83.2	41.6					
	F-06N-	3/8" Female NPT			65.0	30.0					
	F-08N-	1/2" Female NPT			65.0	32.5					
	M-08N-	1/2" Male NPT			66.0	33.0					
	MF-08N-	1/2" Male NPT 1/2" Female NPT			66.0	33.0					
VN55	U-16T-	1" UNILOK	12.7	3.20	99.2	49.6	20.0	20.0	86.7*	85*	29.0
	F-12N-	3/4" Female NPT			75.0	37.5					
	F-16N-	1" Female NPT			89.0	44.5					

* Dimensions for bar handle. Round handle for these sizes are not available.
ISO7/1 Tapered Threads (PT) are available for all fractional sizes of VN5 series valves.
Add "R" as a suffix instead of "N".

Dimensions are for reference only and are subject to change without prior notice.

VN5 series

(Straight Pattern, Male/UNILOK Tube Fitting or Both Tube or Pipe Socket Welds)

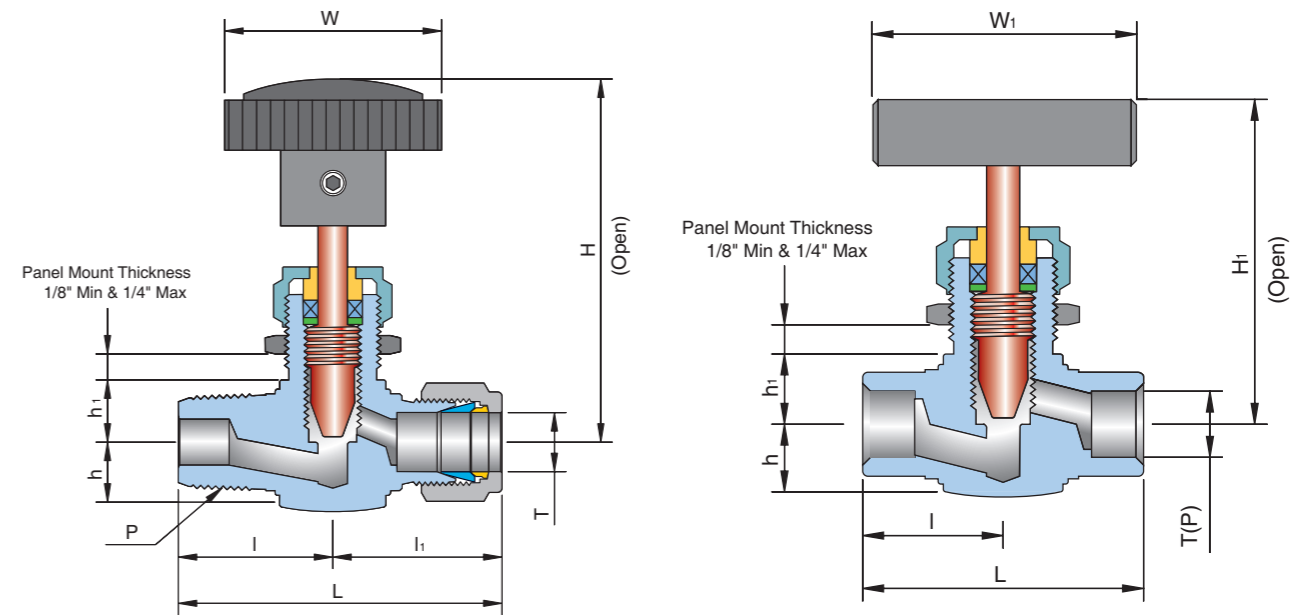

Ordering Information & Dimensions

Part No.	End Connections		Orifice	CV	Dimensions (mm)					Panel Hole Drill Size	
	Inlet	Outlet			L	I	h	h ₁	Bar Handle H ₁ (open) W ₁		
VN52	MU-04N02T-	1/4" Male NPT 1/8" UNILOK	4.3	0.37	51.3	25.0	9.5	9.5	54.3	45.0	13.5
	MU-04N04T-	1/4" Male NPT 1/4" UNILOK			53.3	25.0					
	WS-04T	1/4" Tube			42.0	21.0					
VN53	MU-04N06T-	1/4" Male NPT 3/8" UNILOK	6.3	0.73	60.4	26.5	12.5	13.5	67.5	50.6	20.0
	MU-06N06T-	3/8" Male NPT 3/8" UNILOK			60.4	26.5					
	MU-06N08T-	3/8" Male NPT 1/2" UNILOK			63.1	26.5					
	WS-06P	3/8" Tube			54.0	27.0					
VN54	WS-08P	1/2" Tube	9.5	1.80	54.0	27.0	17.0	17.0	83.8	62.5	23.0
	WS-04P	1/4" Pipe			54.0	27.0					
	WS-06P	3/8" Pipe			60.0	30.0					
	WS-08P	1/2" Pipe			65.0	32.5					

Male ISO7/1 Tapered Threads (PT) are available for all fractional sizes of VN5 series valves.
Add "R" as a suffix instead of "N".

Dimensions are for reference only and are subject to change without prior notice.

VN5A series

(Angle Pattern, Both UNILOK Tube Fittings or Both Female Threads)

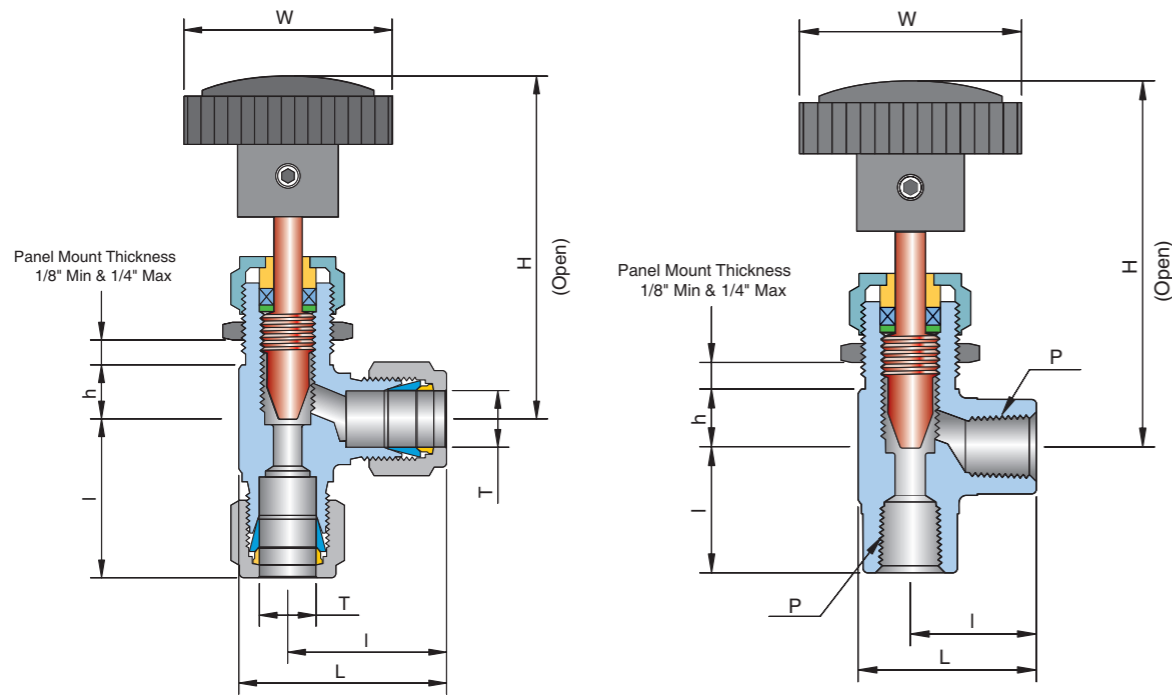

Ordering Information & Dimensions

Part No.	End Connections		Orifice	CV	Dimensions (mm)					Panel Hole Drill Size
	Inlet	Outlet			L	I	h	Round Handle		
								H(open)	W	
VN52A	U-04T-	1/4" UNILOK	4.3	0.37	38.9	30.2	10.1	61.1	34.7	13.5
	U-M06T-	6mm UNILOK			39.1	30.5				
	U-M08T-	8mm UNILOK			39.3	30.7				
	F-02N-	1/8" Female NPT			29.6	21.0				
VN53A	U-06T-	3/8" UNILOK	6.3	0.73	44.2	33.1	12.2	78.4	46.7	20.0
	U-08T-	1/2" UNILOK			46.9	35.8				
	U-M10T-	10mm UNILOK			44.8	33.7				
	U-M12T-	12mm UNILOK			46.9	35.8				
	F-04N-	1/4" Female NPT			37.0	26.0				
VN54A	F-06N-	3/8" Female NPT	9.5	1.80	53.5	39.7	15.9	92.2	55.5	23.0
	F-08N-	1/2" Female NPT								

Female ISO7/1 Tapered Threads (PT) are available for all fractional sizes of VN5 series valves. Add "R" as a suffix instead of "N".

Dimensions are for reference only and are subject to change without prior notice.

Pressure - Temperature Ratings by Packing Materials

Body Material	Stem	PTFE packing				PEEK packing			
		Temperature Rating		Pressure Rating		Temperature Rating		Pressure Rating	
		°C	°F	psig	bar	°C	°F	psig	bar
316SS	metal to metal (vee & regulating)	-54~232	-65~450	5000	345	-54~315	-65~600	3130	215
	soft-seat (Kel-F)	-54~93	-65~200			-54~93	-65~200		
Brass	metal to metal (vee & regulating)	-54~204	-65~400	3000	207	-54~204	-65~400	3000	207
	soft-seat (Kel-F)	-54~93	-65~200			-54~93	-65~200		
Alloy 400	metal to metal (vee & regulating)	-54~232	-65~450	3000	207	-54~260	-65~500	2370	162
	soft-seat (Kel-F)	-54~93	-65~200			-54~93	-65~200		

Packing adjustment to be required for extreme temperature variations. For the service with aromatic heat transfer fluids or concentrated sulfuric and nitric acids, PEEK is not recommended.

Working Pressure at Temperature

	Temperature		Working Pressure							
	°C	°F	316SS		Brass		Alloy 400			
			psig	bar	psig	bar	psig	bar		
-54 to	38	-65 to	100	5000	345	3000	207	3000	207	
	93		200	4290	296	2600	180	2640	183	
	148		300	3870	267	2210	153	2470	171	
	176		350	3710	256	1470	102	2430	168	
	204		400	3560	246	740	52	2390	165	
	232		450	3430	237	-	-	2380	165	
Materials			316SS		Brass		Alloy 400			

Number of Handle Turns - Flow Coefficient (Cv)

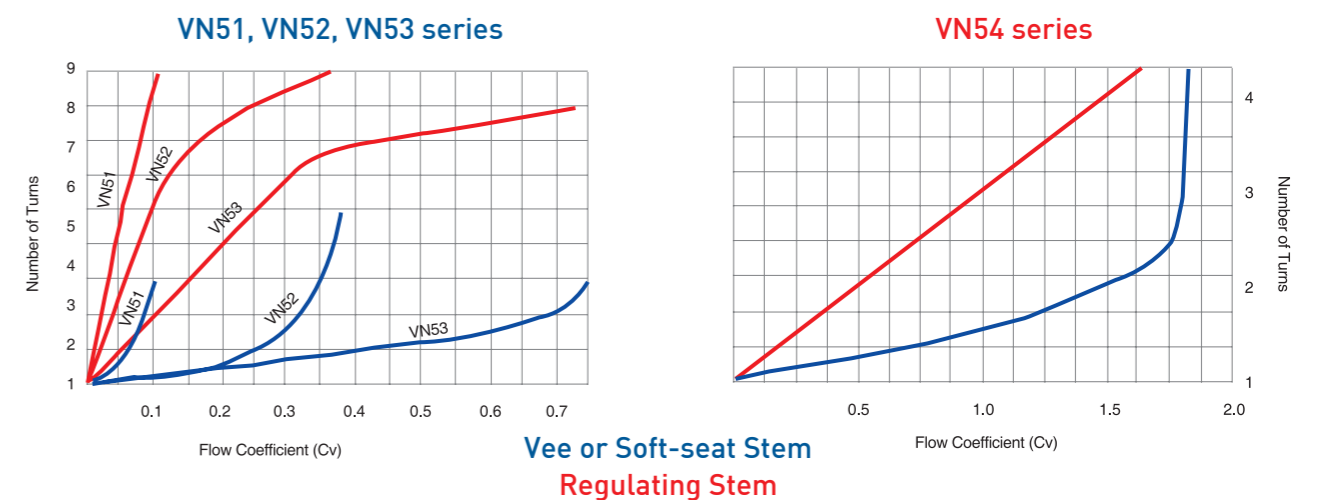

Stem Types

Metal to metal vee stem is standard for pressure tightness even at elevated temperature. Regulating stem and soft-seat stem with KEL-F are available as optional.

The excessive force when closing valve may damage both seat and stem tip, particularly soft-seat stem.



Vee Stem
Pressure tightness at elevated temperature

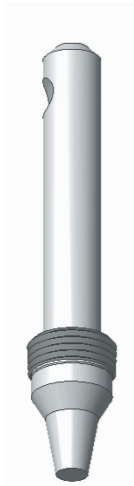

Regulating Stem
Flow rate control



Soft-seat Stem
Repetitive shut-off for gas

Handle Types

Black nylon round handle is standard.

For the valves with brass body and soft-seat stem, standard round handle is recommended.

Optional stainless steel bar handle is available.

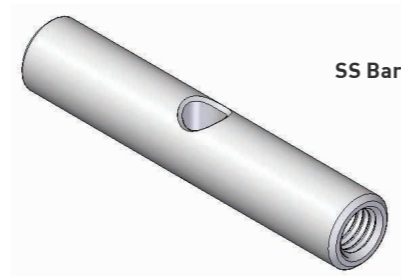

SS Bar Handle

INSTRUMENT

High Pressure Bar Stock Needle Valves VN6



Features

- Pressure rating up to 6000psig (413bar) @38°C(100°F)
- Temperature rating from -53°C(-65°F) to 232°C(450°F) with standard PTFE packing, up to 315°C(600°F) with PEEK packing
- High temperature application is available Grafoil packing, up to 648°C(1200°F)
- Compact body design
- Hardened stem threads and forged body for long cycle life
- Integral bonnet design to eliminate unintentional stem back-out
- Stop pin to prevent accidental bonnet disengagement

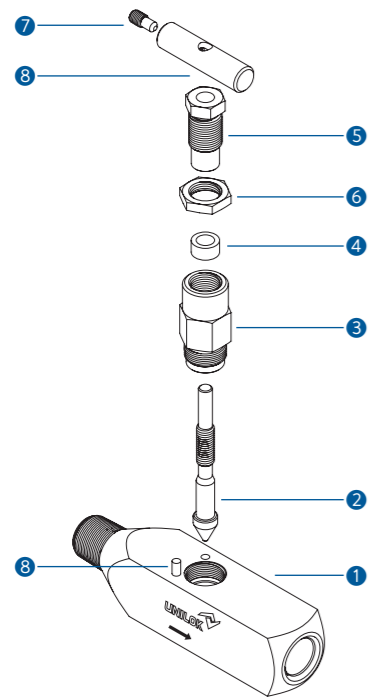
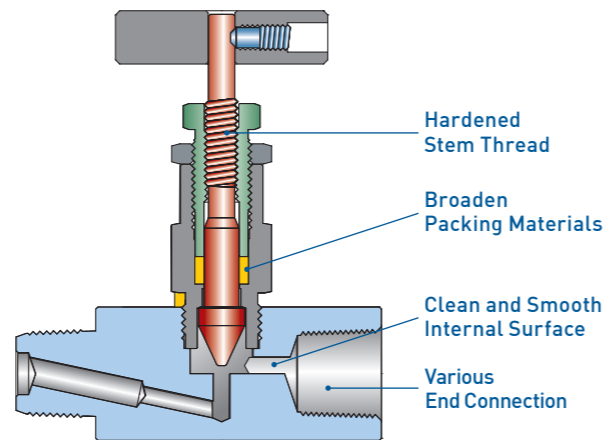

Materials of Construction

No.	Description	Materials	
Body Material		316SS	Alloy 400
1	Body	316SS	Alloy 400
2	Stem	316SS	Alloy R-405/B164
3	Body Bonnet	316SS	Alloy R-405/B164
4	Packing	PTFE	
5	Spindle Bushing	316SS	Alloy R-405/B164
6	Jam Nut	316SS	Alloy R-405/B164
7	Set Screw	304SS	
8	Bar Handle	304SS	
9	Stop Pin	304SS	

Pressure - Temperature Rating

Body Material	Stem	PTFE packing			
		Temperature Rating		Pressure Rating @ 38°C	
		°C	°F	psig	bar
316SS	Vee (metal to metal)	-54~232	-65~450	6000	413
	Soft-seat (Kel-F)	-54~93	-65~200		
Alloy 400	Vee (metal to metal)	-54~232	-65~450	5000	345
	Soft-seat (Kel-F)	-54~93	-65~200		

Packing Material	Body Material	Temperature Rating		Pressure Rating @ Max. Temperature	
		°C	°F	psig	bar
PTFE	316SS	-54~232	-65~450	4130	285
	Alloy 400			3970	274
PEEK	316SS	-54~315	-65~600	3760	260
	Alloy 400	-54~260	-65~500	3960	273

For the service with aromatic heat transfer fluids or concentrated sulfuric and nitric acids, PEEK is not recommended.

Application

Severe service application, steam service in power plant, hot condensates

Sour Environment Services

UNILOK valves comply with NACE MR-0175/ISO 15156 for sour oilfield application or NACE MR-0103 for petroleum refining operations. To order, add -N to the end of part number.

Cleaning

UNILOK valves are free from machine oils, loose particles and grease throughout the close cleaning process.

How To Order

UNILOK VN6 series needle valves are ordered by part number as shown below.

Testing

Every valve is 100% factory tested with air and nitrogen at 1000psig(69bar) for leakage at the seat and packing. Each test is performed to a maximum allowable leak rate of 0.1scc/min.

Important Notification

Proper installation, materials compatibility, operation and maintenance of these valves are the responsibility of the user. The total system design must be taken into consideration to ensure optimal performance and safety. The packing adjustment may be required during the valve's service life.

Example: The following part number, *VN62MF-04N-SS* is designated for VN6 series needle valve with 1/4" male NPT to 1/4" female NPT, 316SS.



Connection Type	
U	UNILOK Tube Fitting
F	Female NPT or ISO7/1(PT)
M	Male NPT or ISO7/1(PT)

Connection Size				
Fractional(Inch) Tube O.D. Designation				
Tube O.D.	inch	1/4	3/8	1/2
	mm	6.35	9.52	12.70
Designator		04T	06T	08T

Body Materials	
SS	316SS
MO	Alloy 400

Metric Tube O.D. Designation					
Tube O.D.	mm	6	8	10	12
	Designator	M06T	M08T	M10T	M12T

Stem Type	
None	Vee Stem
S	Soft Seat Stem

Pipe Size Designation (NPT or ISO7/1-PT)			
Pipe Size	1/4	3/8	1/2
Designator	04N/R	06N/R	08N/R

Packing Materials	
None	PTFE
PK	PEEK
GF	Grafoil

VN6 series

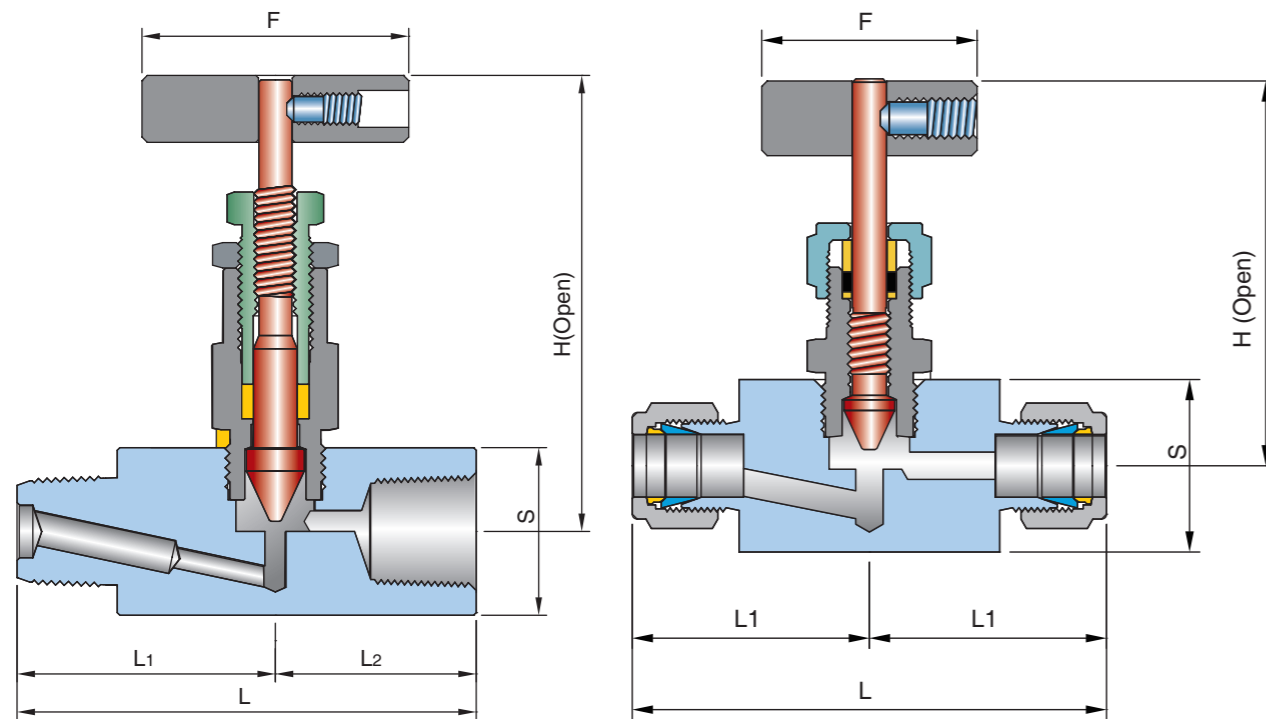

INSTRUMENT

Union Bonnet Valves VU6

Ordering Information & Dimensions

Part No.	End Connections		Orifice	CV	Dimensions (mm)					
	Inlet	Outlet			L	L ₁	S	F	H	
VN61	U-04T-	1/4" UNILOK		4.0	0.35	76.2	38.1	25.4	45.0	56.7
	U-06T-	3/8" UNILOK								
	U-08T-	1/2" UNILOK								
	U-M06T-	6mm UNILOK								
	U-M08T-	8mm UNILOK								
	U-M10T-	10mm UNILOK								
	U-M12T-	12mm UNILOK								
VN62	F-04N-	1/4" Female NPT		4.0	0.35	76.2	38.1	32.0	50.6	86.5
	F-06N-	3/8" Female NPT								
	F-08N-	1/2" Female NPT								
	MF-04N-	1/4" Male NPT	1/4" Female NPT							
	MF-06N-	3/8" Male NPT	3/8" Female NPT							
	MF-08N-	1/2" Male NPT	1/2" Female NPT							

ISO7/1 Tapered Threads (PT) are available for all fractional sizes of VN6 series valves. Add "R" as a suffix instead of "N".

Dimensions are for reference only and are subject to change without prior notice.



Union Bonnet Valves VU6

CONTENTS

Features	162	How To Order	163
Materials of Construction	162	Ordering information & Dimensions	164
Application	163	Stem Types	166
Cleaning	163	Panel Mounting Procedure	166
Testing	163	Pressure-Temperature Rating	166

Features

- Pressure rating up to 6000psig (413bar) @38°C (100°F)
- Temperature rating from -53°C(-65°F) to 232°C (450°F) with standard PTFE packing, up to 648°C (1200°F) with Grafoil packing
- Roll threaded and hardened stem for long cycle life
- Union bonnet design to ensure high integrity seal under severe environments
- Panel mounting without packing disruption

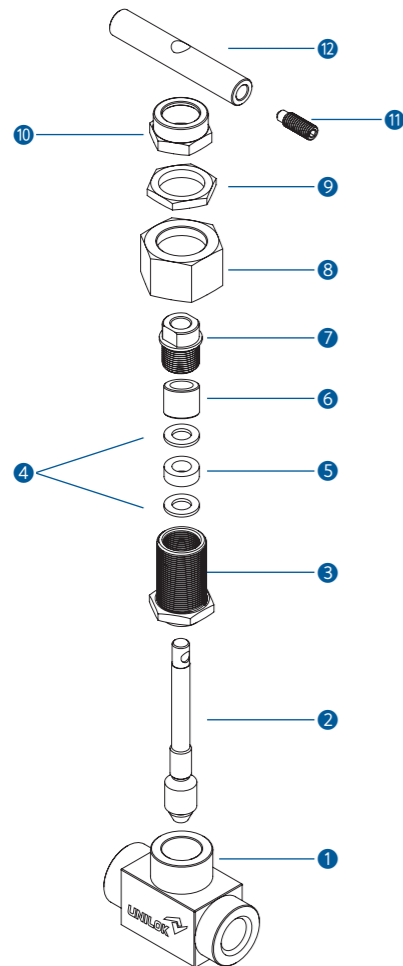
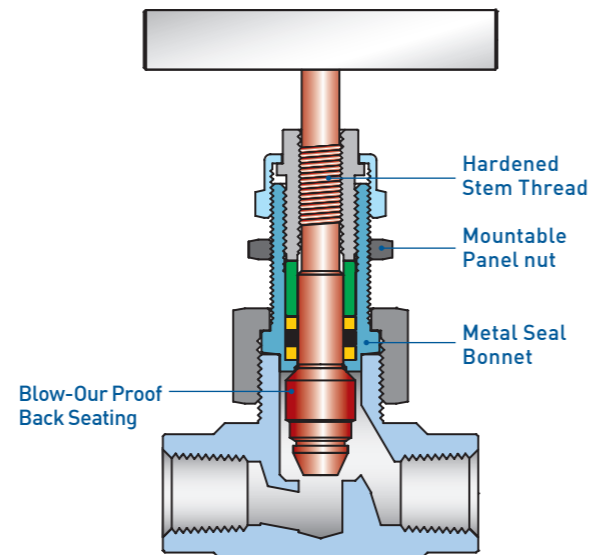

Materials of Construction

No.	Description	Materials	
	Body Material	316SS	Alloy 400
1	Body	316SS	Alloy 400
2	Stem	316SS	Alloy R-405/B164
3	Bonnet	316SS	Alloy R-405/B164
4	Packing Support	Glass-filled PTFE	
5	Packing	PTFE	
6	Gland	316SS	Ally R-405/B164
7	Packing Bolt	316SS	Alloy R-405/B164
8	Panel Nut	316SS	Alloy R-405/B164
9	Union Nut	316SS	Alloy R-405/B164
10	Lock Nut	316SS	Alloy R-405/B164
11	Set Screw	304SS	
12	Handle	304SS	

Application

Severe service application, high pressure sampling and shut-down systems, test stands

Sour Environment Services

UNILOK valves comply with NACE MR-0175/ISO 15156 for sour oilfield application or NACE MR-0103 for petroleum refining operations. To order, add-N to the end of part number.

Cleaning

UNILOK valves are free from machine oils, loose particles and grease throughout the close cleaning process.

How To Order

UNILOK VU6 series union bonnet valves are ordered by part number as shown below.

Testing

Every valve is 100% factory tested with air and nitrogen at 1000psig(69bar) for leakage at the seat and packing. Each test is performed to a maximum allowable leak rate of 0.1scc/min.

Important Notification

Proper installation, materials compatibility, operation and maintenance of these valves are the responsibility of the user. The total system design must be taken into consideration to ensure optimal performance and safety. The packing adjustment may be required during the valve's service life.

Example: The following part number, *VU62F-04N-SS* is designated for VU6 series union bonnet valve with 1/4" female NPT to 1/4" female NPT, 316SS.



Valve Type	
U6	Straight Pattern
U6A	Angle Pattern

Connection Size							
Fractional(Inch) Tube O.D. Designation							
Tube O.D.	inch	1/8	1/4	3/8	1/2	3/4	1
	mm	3.17	6.35	9.52	12.70	19.05	25.40
Designator		02T	04T	06T	08T	12T	16T

Body Materials	
SS	316SS
MO	Alloy 400

Other alloys are available upon request.

Connection Type	
U	UNILOK Tube Fitting
F	Female NPT or ISO7/1(PT)
M	Male NPT or ISO7/1(PT)
WS-	Socket Weld -Tube
WS-	Socket Weld - Pipe

Metric Tube O.D. Designation					
Tube O.D.	mm	6	8	10	12
Designator		M06T	M08T	M10T	M12T

Stem Type	
None	Lee Stem
R	Regulating
S	Soft-seat
B	Ball

Pipe Size Designation (NPT or ISO7/1-PT)						
Pipe Size	1/8	1/4	3/8	1/2	3/4	1
Designator	02N/R	04N/R	06N/R	08N/R	12N/R	16N/R

Packing Materials	
None	PTFE
PK	PEEK
GF	Grafoil

Weld Size Designation				
Tube Size	1/4	3/8	1/2	3/4
Designator	04T	06T	08T	12T
Pipe Size	1/4	3/8	1/2	
Designator	04P	06P	08P	

VU6 series

(Straight or Angle Pattern, Both UNILOK Tube Fittings or Both Tube or Pipe Socket Welds)

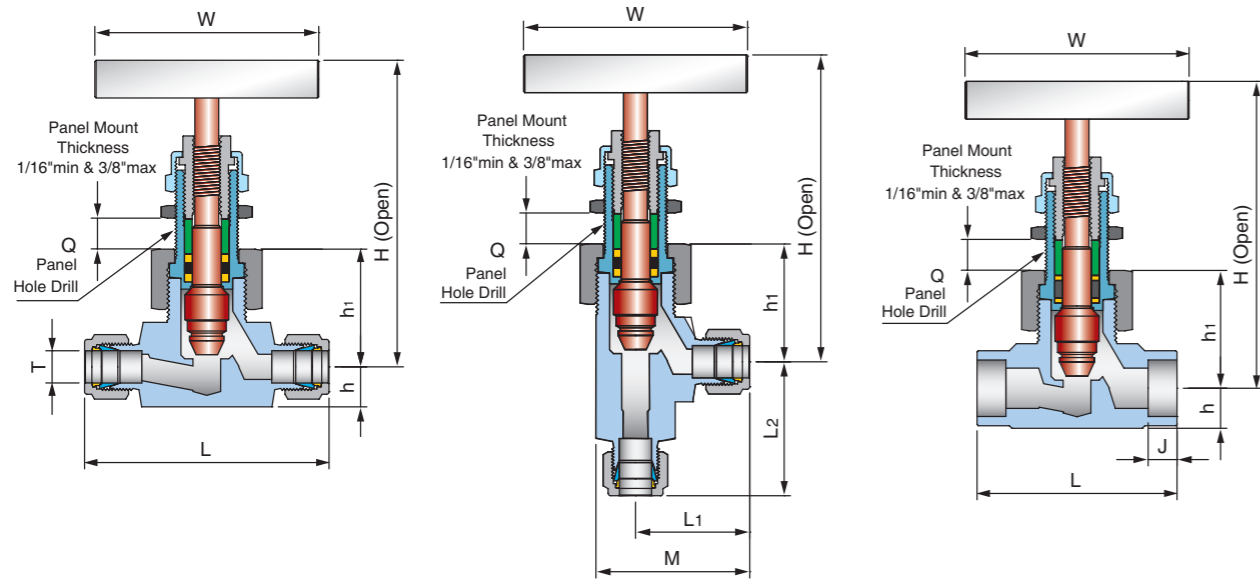

VU6 series

(Straight or Angle Pattern Both Female or Male Threads or Male/Female Thread)

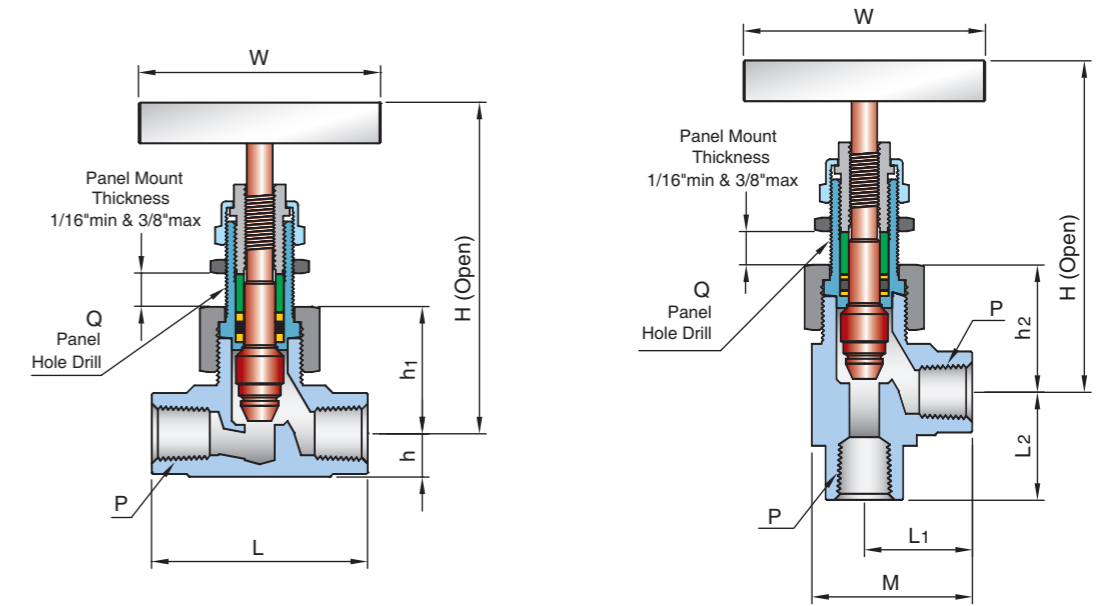

Ordering Information & Dimensions

Part No.	End Connections		Orifice	CV	Dimensions (mm)											
	Inlet	Outlet			L	L ₁	L ₂	M	h	h ₁	h ₂	H _(open)	W	Q	J	
VU61	U-04T-	1/4" UNILOK	4.0	0.35	61.9	29.4	37.3	38.9	9.6	27.8	27.8	77.8	45.0	15.1	-	
	U-M06T-	6mm UNILOK			46.0	22.3	30.2	31.8							7.2	
	U-M08T-	8mm UNILOK														
	WS-04T	1/4" Tube SW														
VU62	U-06T-	3/8" UNILOK	6.4	0.86	73.0	32.5	42.9	45.3	12.7	34.1	34.2	93.7	64.0	19.9	-	
	U-08T-	1/2" UNILOK			77.8	34.9	42.1	47.6							31.0	34.2
	U-M10T-	10mm UNILOK			73.0	33.3	39.7	46.1							34.2	
	U-M12T-	12mm UNILOK			77.8	35.7	42.1	48.4							37.3	8.0
	WS-06T	3/8" Tube SW			57.2	25.4	28.6	38.1							35.7	9.6
	WS-08T	1/2" Tube SW			57.2	25.4	25.4	38.1							37.3	
WS-04P	1/4" Pipe SW	57.2	25.4	28.6	38.1											
VU63	U-08T-	1/2" UNILOK	11.0	2.20	98.0	43.7	53.2	61.1	15.9	46.0	47.6	121.5	89.0	26.2	-	
	U-12T-	3/4" UNILOK			100.0	-	-	-							47.6	47.6
	U-16T-	1" UNILOK														
	U-M12T-	12mm UNILOK			98.0	43.7	53.2	61.1							47.6	121.5
	WS-08T	1/2" Tube SW			79.4	33.3	42.9	50.8							47.6	9.6
	WS-12T	3/4" Tube SW			79.4	-	-	-							47.6	11.1
WS-08P	1/2" Pipe SW	79.4	33.3	39.7	50.8	50.8	9.6									

Dimensions are for reference only and are subject to change without prior notice.

Ordering Information & Dimensions

Part No.	End Connections		Orifice	CV	Dimensions (mm)												
	Inlet	Outlet			L	L ₁	L ₂	M	h	h ₁	h ₂	H _(open)	W	Q			
VU61	F-02N-	1/8" Female NPT	4.0	0.35	50.8	23.0	25.4	32.6	9.6	27.8	32.6	77.8	45.0	15.1			
	F-04N-	1/4" Female NPT			52.4	26.2	23.0	32.6									
	M-04N-	1/4" Male NPT			50.8	25.4	25.4	35.0									
	MF-04N-	1/4" Male NPT 1/4" Female NPT			52.4	23.0	25.4	32.6									
VU62	F-04N-	1/4" Female NPT	6.4	0.86	57.2	25.4	28.6	38.1	12.7	34.1	37.3	93.7	64.0	19.9			
	F-06N-	3/8" Female NPT															
VU63	F-08N-	1/2" Female NPT	11.0	2.20	79.4	33.3	39.7	50.8	15.9	46.0	50.8	121.5	89.0	26.2			
	F-12N-	3/4" Female NPT			82.6	-	-	-							19.9	48.4	-
	F-16N-	1" Female NPT			92.1	-	-	-							25.4	54.0	-
	MF-08N-	1/2" Male NPT 1/2" Female NPT			79.4	33.3	39.7	50.8							15.9	46.0	50.8
	MF-12N-	3/4" Male NPT 3/4" Female NPT			82.6	-	-	-							19.9	48.4	-
	MF-16N-	1" Male NPT 1" Female NPT			92.1	-	-	-							25.4	54.0	-

ISO7/1 Tapered Threads (PT) are available for all fractional sizes of VU6 series valves. Add "R" as a suffix instead of "N".

Dimensions are for reference only and are subject to change without prior notice.

Stem Types

Metal to metal vee stem is standard for pressure tightness even at elevated temperature. Regulating stem, ball stem and soft-seat stem with KEL-F are available as optional. The excessive force when closing valve may damage both seat and stem tip, particularly soft-seat stem.

Vee, regulating, ball and soft-seat are non-rotating stems.

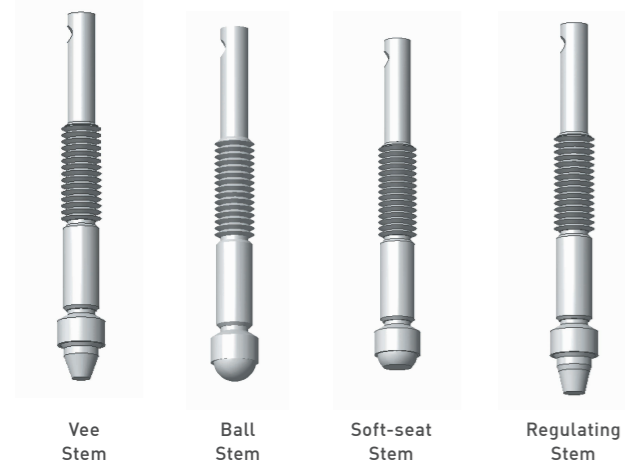

Panel Mounting Procedure

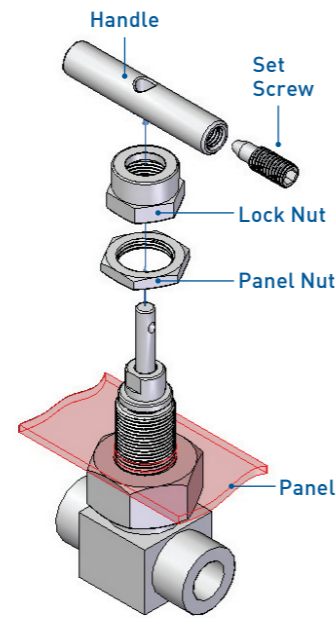

Loose handle set screw using appropriate allen key.

Disassemble Lock nut and panel nut.

Insert the valve into the panel hole.

Tighten panel nut and Lock nut onto the valve bonnet.

Reassemble handle.

Tighten panel nut when fully closing of the valve.

Pressure -Temperature Rating

Body Material	Stem	PTFE packing			
		Temperature Rating		Pressure Rating @ 38°C	
		°C	°F	psig	bar
316SS	Vee, Ball, Regulating	-54~232	-65~450	6000	413
	Soft-seat (Kel-F)	-54~93	-65~200		
Alloy 400	Vee, Ball, Regulating	-54~232	-65~450	5000	345
	Soft-seat (Kel-F)	-54~93	-65~200		

Packing Material	Body Material	Temperature Rating		Pressure Rating @ Max. Temperature	
		°C	°F	psig	bar
PTFE	316SS	-54~232	-65~450	4130	285
	Alloy 400	-54~232	-65~450	3970	274
PEEK	316SS	-54~315	-65~600	3760	260
	Alloy 400	-54~260	-65~500	3960	273
Grafoil	316SS	-54~648	-65~1200	1715	119
	Alloy 400	-54~260	-65~500	3960	273

Alloy 400/Monle is not applicable over 260°C(500°F)

For the service with aromatic heat transfer fluids or concentrated sulfuric and nitric acids, PEEK is not recommended.