

NP-PF Series

For Cylinder, No Heater type Carbon Dioxide Pressure Regulator

Specifications

Outlet Pressure Gauge	0.5MPa	Proof Pressure	0.15MPa
Inlet Pressure	12MPa or less	Inlet Connection	W22-14 O.R.
Outlet Pressure	0.15MPa	Outlet Connection	Hose Nipple 8.5mm
Flow Range	1 ~ 25L/min	Accessories	Gasket Packing(Fiber)×2Pcs.
Type of Flowmeter	IN	Approximate Weight	2.4kg

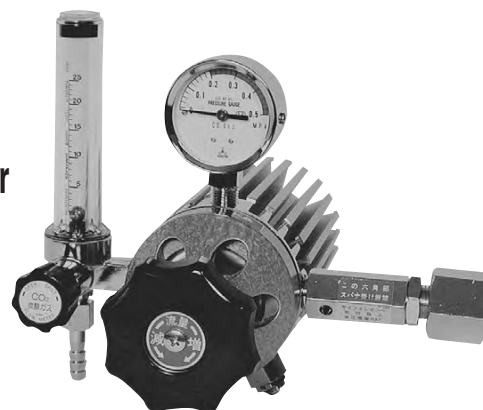

Outline drawing

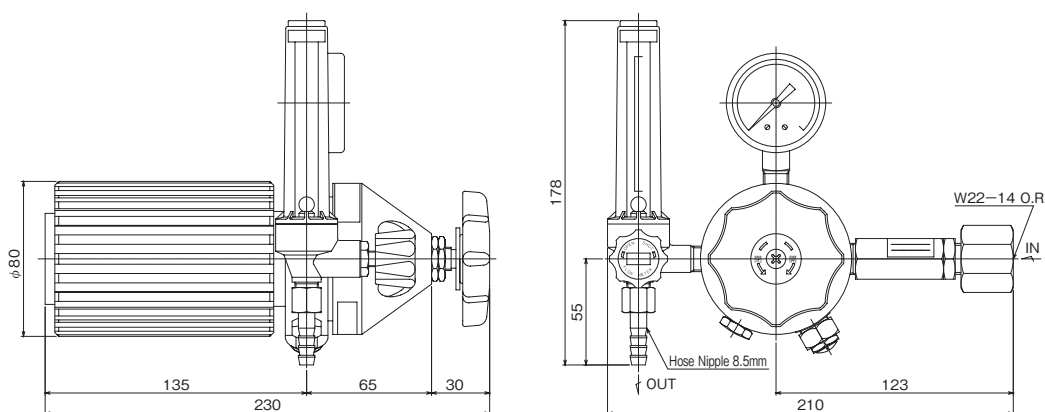

[Note]
 ■ Unit : mm
 ■ Dimensions are subject to change without notice.

Supply pressure effect characteristics

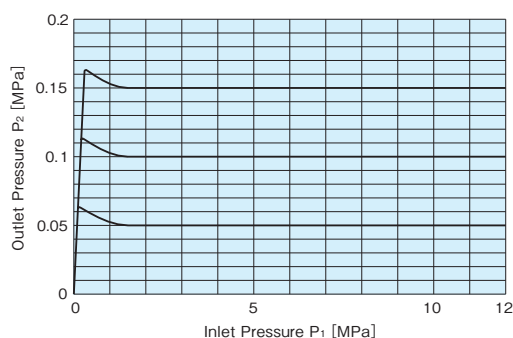

[Note]
 ■ These tests were performed at ambient conditions.

Materials of construction

Body	C3771BE
Bonnet	ADC12
Fin cover	A6063S-T5
Poppet	C3604BD
Seat	PTFE
Diaphragm	Phosphor bronze
Safety valve seat	NBR

List of specifications

Series	Outlet Pressure Gauge MPa	Flowmeter				Inlet Connection	Outlet Connection
		Applicable gas	Flow L/min	Type of Flowmeter	Proof Pressure MPa		
NP-PF	0.5	CO ₂	25	IN	0.15	W22(R)	Hose Nipple 8.5mm
	0.5	CO ₂	25	IN	0.15	W22(R)	UNF9/16-18 Male
	0.5	CO ₂	25	IN	0.15	W22(R)	Rc1/4
	0.5	CO ₂	25	IN	0.15	Yoke Connection	Hose Nipple 8.5mm